

DEC 07

News from
Barton MFC
Lancashire Aero Club
Model Aero Engineers

Free to members

Vol 9 Issue 4

Circle Talk

www.controlline.org.uk

THE GHOSTS OF OPEN GOODYEAR



What's coming up at BARTON?

DECEMBER 2007

7th - Barton Clubnight
Bring your new model/engine!

28th - Barton Racing
Cold Turkey Day (Friday)
Barton B/BGY/MGY/Club Speed
Malcolm Ross 0192 576 6610

JANUARY 2008

11th - Ladies Night
Boysnope Hall Golf Club (Friday)
See "Notice Board" on back cover

Open Goodyear Day at Barton, 14th October 2007. Reports elsewhere of Open Goodyear's demise should be regarded as premature to judge by this storming competition. Our photo may have been posed but the flyers' obvious enthusiasm for this "dead" event most certainly was not.

It's true that most aeromodellers who go through life with an enquiring mind rarely appreciate her...

[Pictured above - Back row L-R: Martin Worgan, Peter Jephcott, John Catlow, Mike Crossman, Andy Dalglish (CD), Mike Bellamy, Lawrence Court, Dave Robson, Nev Eyre, Dave Hutchison, Chris Eifflaender; Front row L-R: Paul McPeake, Tony Eifflaender, Peter Cannon, Derek Cannon, Tom Meager]

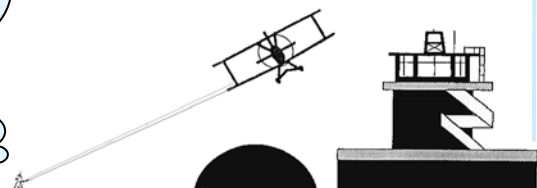

Club News

DECEMBER CLUB NIGHT – *Important!*

Please note that this has been moved forward one week to Friday, 7th December because of a double booking at *The Brown Cow*. Lenny urges you to bring along your new models or that bargain engine from that swap meet to show off and talk about it. (We wanna see it - before you break it!).

NEW MEMBERS

A warm welcome to all of our new members – Paul McPeake, Steve Lewin, D.E. Benjamin, Derek Cannon, Robert Cunningham, Irvine Elia, Stuart Feeney, David Hutchison, S.C. Kimsey and Robert Rae (*Country Members*); John Daly, Andy Daglish, Ken Fleming, Paul Forrester and David Robson (*Full Members*); and Alex and Nicholas Feeney and R.J. Wild (*Junior Members*). Use those circles!

SUBSCRIPTIONS DUE

Existing members! If you have yet to pay up, please note that your subscriptions are now well overdue. The club needs your subscription money right now in order to keep going forward! Please do it now! The rates for the 2007-08 season are as follows:

Full Member	£40.00
Country Member	£20.00
Junior Member	£5.00

BARTON AGM *12th October*

Well attended, with the majority of the proceedings taken up by discussions of the coming year's budget and the level at which membership fees should be pegged.

Regarding fees, it was apparent that not only was there an admitted "difference of opinion" within the Committee, but neither was there any consensus among the membership, as some favoured no increase at all while others wanted to hedge against "unexpected future expenditure". In the end, it was a modest increase of £1.50 that received an overwhelming majority vote. For purposes of checking insurance renewals when there were so many BMFC members with dual membership of other clubs (and prompted by the laughter provoking confession of an oversight by a well-known member) there was agreed to be some advantage in delaying the timing of future AGMs until December (when BMFA annual membership expires).

The evening was the opportunity for one or two announcements. The affiliation to the Lancs Aero Club was to be maintained (at no cost to BMFC). Brian Winstanley's end of season airfield working parties would be recommencing that October.

The Barton Forum under Jim Hatch's administration now had an on-line membership of 800. The industrious Len Morrall's club raffles had brought in almost £750 income! In January 2008 there would be a re-run of last years successful "Ladies Night". [See "Notice Board" on back page - Ed].

A static caravan was soon to be brought on to the site to provide shelter, space for this being provided by the removal of the PFA's container. However, under the terms of our agreement with Peel Holdings, BMFC were not permitted any works that had any semblance of "permanency" on-site... for example, this even included a water main (considered to be an essential by many members), never mind the much desired toilet block.

An animated discussion about safety produced a number of comments from members re the pros and cons of the line checks undertaken constantly under the Safety Officer's ever-watchful eye. The President pointedly reminded all present that "everyone should regard themselves as a safety officer" and should not be afraid to take action to ensure that the club was never put into jeopardy.

Malcolm Ross had opened the meeting by explaining why he found himself in the Chair for the evening, referring to the sudden and enforced retirement of John Kergon through ill-health and to whom he paid full tribute for his considerable input. Lawrence Court was elected unopposed as Chairman. Malcolm Ross was willing to continue as Secretary, there being no other nominations. David Goddard had also been indisposed for some considerable time following his serious medical problems and, there being no other takers, John Whiteside volunteered to replace him as PRO. Len Morrall badly wanted to step down as Social Activities Secretary ("feeling jaded") but had been such a success during his two years that he was absolutely *not* permitted by the meeting to retire!

Trophies were awarded as follows: *Senior Trophy* to Tony Eifflaender after an outstandingly successful year in competition; *Junior Trophy* to Tom Meager, who had made such great progress; and *Fred Holden Award* to Jim Hatch for his many hours spent organising the web site. A *BMFA Medal* went to Peter Grange following many years meritorious service as combat champ Mike Whillance's pitman.

MEMBERSHIP CARDS

A number of members who have renewed have yet to be issued with membership cards. If this applies to you, please notify Pat Winstanley.

OBSERVED AT THE BROWN COW

In September...

The main feature was a well attended and informative talk by Mike Fitzgerald on manufacturing carbon fibre propellers

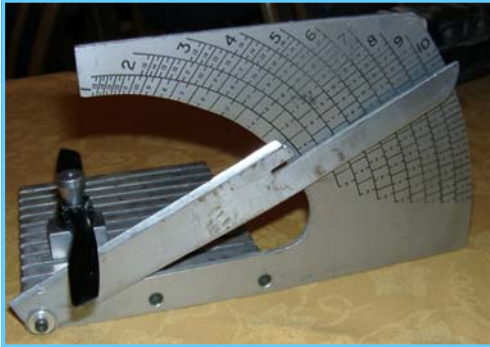

Useful looking bit of kit [above] was this pitch gauge. At the AGM a month later, Mike makes a point [below] to new Chairman Lawrence Court.



[Above right] Geoff and Harry Walker's first venture into Speed (following Geoff's retirement from active Team Racing) was this Sadler "Little Rocket" with Super Tigre G31 1.5 cc diesel. For their second, [above left] it's a G20 glow powered "A Jewel", Larry Grogan's US Nats winner.

At the AGM in October...

After the main business was over, there was still plenty of time for a natter as always



Awarded annually to a member who puts in a lot of effort behind the scenes for the club, the Fred Holden Award here goes to Jim Hatch [seen above on right].

Ken Morrissey [below] explains to Malcolm Ross what will happen if someone tips that green salad over his hair again. Derek Heaton keeps schtum.



John Bradley [on left above] makes a point to Tony Eifflaender. Ian Taylor, in background, eyes up an unattended platter of chips.

Tony receives Senior Trophy [left] from Ken Morrissey.

Ken Morrissey presents BMFA Medal to ace combat pitman Peter Grange [below]



All photos on this page by Fred Hall



Racing

BARTON GOODYEAR MEETINGS

British & Mini Goodyear, 8th July

Tony Eifflaender reports:

British Goodyear

The event was reasonably well attended with six entries, holidays being the barrier to some teams being able to enter. Not being present myself, I cannot provide a blow by blow account but can tell you that there were some good performances. *Eyre/Winstanley* did a 4:53 in Heat 2 (a personal best?) while *Daglish/Worgan* recorded a 4:29 in the same heat. Judging by the result sheets, it rained later in the day. The final results were as follows.

BRITISH GOODYEAR (6 entries)

Pos	Team	TIME
1.	Daglish/Worgan	9:58
2.	McPeake/Bellamy	10:19
3.	Eyre/Winstanley	10:50

Mini Goodyear

Another poor entry of just four and the final was once again scrappy.

MINI GOODYEAR (4 entries)

Pos	Team	TIME
1.	Daglish/Morrall	9:09
2.	Cannon/Bradley	Retired
3.	Eyre/Winstanley	Retired

[Photos of the above in last issue – Ed]

British Goodyear, 5th August

Tony Eifflaender reports:

Eight eager teams turned out for a pre-Nats sort out. The weather gods were kind, blessing us with near perfect conditions for racing.

Round 1

Heat 1 set the pace with *Eifflaender/Eifflaender* (4:31) and *Daglish/Worgan* (4:34), with *Millar/Court* running in with a 6:01.

Heat 2 saw *Eyre/Winstanley* going well with a 5:12, a slow 6:02 for the *Cannons* and some trouble for *Bowman/Blaine*.

Heat 3 was a two-up in which *Meager/Bellamy* retired at 48 laps but *Eyre/McPeake* recorded a fast 5:07.

Round 2

Heat 1 brought a rare occurrence, a retirement by *Daglish/Worgan*. *Eyre/McPeake* again showed good pace with 5:11 but there was to be no improvement by *Eifflaender/Eifflaender* (4:38).

Heat 2 was where the middle order picked up the pace with 5:48 by *Bowman/Blaine* and 5:23 by *Eyre/Winstanley*.

Heat 3 saw the *Cannon* brothers go out on 75 laps, while *Meager/Bellamy* returned a quick 4:45.

Round 3

Heat 1 had *Millar/Court* improving to 5:01, agonisingly close to a final slot! The *Cannons* suffered further problems but *Meager/Bellamy* showed good consistency with another sub-five minute time of 4:46. The rest of the teams either sat out Round 3 or had problems – with the exception of the *Cannons*, who finally recorded a steady 5:38.

The Final

The top three teams of *Eifflaender/Eifflaender*, *Daglish/Worgan* and *Meager/Bellamy* all got well away at the start, promising a close race. However, disaster struck for the *Eifflaenders* at Lap 97 when Chris' handle got stuck on Martin Daglish's shirt, causing a serious crash for the *Eifflaenders*, who were out! This left the two Martins in a lead that they were not to lose, *Meager/Bellamy* finishing a superb 2nd in young Tom's first Final. (Well done, Tom!).

BRITISH GOODYEAR (8 entries)

Pos	Team
1.	Daglish/Worgan
2.	Meager/Bellamy
3.	Eifflaender/Eifflaender

Finally, a big thank you is due to Martin Worgan and Andy Daglish for directing another fine contest – not forgetting thanks also to all the helpers from Barton MFC. **AE**

*A perplexed Goodyear pit man at Barton
Found his engine went balky when starton.
Home-brewed fuel was the cause of his toil,
Since he would use Medicinal Castor Oil...
No wonder his engine was apoppin' 'n' afarton!*

*Came along a guy to help from F2C.
"I do think I know the answer" said he.
"You see the problems you've caused
(A sort of straight-through exhaust)
When using Castor and Liquid Paraffin BPC!"*

*Then shouted the pilot "Oy, I'm not to blame
But you're perfectly right. What a shame!
You can forget any more flights,
Until I've changed these damp tights.
'Cos I think I've had a dose of the same!*

PFA NW STRUT



Hot and Cold Buffet

Tickets £7.00 each
TUESDAY 11TH DECEMBER
 7.30 pm at

THE BROWN COW HOTEL
 319 Worsley Road, Eccles M30 8BW

Everybody welcome! Book your ticket NOW!

Contact Susan Dunn

T: 01695 422550

E: susanedunne@btinternet.com

Barton MFC members who wish to know more about this or other PFA NW Strut events are recommended to speak to Brian Winstanley

Advertising on the Web Site

Readers who own or manage small businesses are urged by Len Morrall to consider the benefits (both to their business and to the club) to be gained by making use of the very economical advertising available on the Barton Forum site.

Contact Len on 0170 634 1495 for details.

A Message from Julio Isidro

Via Christine Baars and Eep Buys: "Please send my thanks to all the participants at Évora 2007 that contributed flowers for my mother".

BARTON CIRCLES 2008 PROPOSED CALENDAR OF EVENTS

(All on Sundays except as noted)

20 April

Barton BGY/OGY/F2C-N

Contact: Martin Worgan

27 April

Barton B & Classic 15

Contact: John Broadhead

4 May

Barton BGY/OGY/MGY

Contact: Martin Worgan

17-18 May (Sat-Sun)

Barton BASH

(Events to be advised)

Contact: (Stunt) Ray Lloyd

(All other events) Malcolm Ross

1 June

Barton BGY/OGY/F2C-N

Contact: Martin Worgan

29 June

Barton BGY/OGY/MGY

Contact: Martin Worgan

27 July

Barton Racing (No Goodyear)

(Events to be advised but may include Glow Rat)

Contact: Martin Worgan

3 August

Barton BGY/OGY/F2C-N

Contact: Martin Worgan

14 September

F2B (Barton Cup)

Contact: Ray Lloyd

20/21 September (Sat-Sun)

World Cup F2A/F2B/F2C

Contact: Malcolm Ross

28 September

BGY 1000 Laps

Contact: Martin Worgan

12 October

Provisional BGY/OGY/F2C-N

Contact: Jo Halman

?? December

Barton Cold Turkey Racing

(Events to be advised)

Contact: Malcolm Ross

Contact telephone numbers:

John Broadhead 0152 425 1592

Jo Halman 01582 424398 Ray Lloyd 0170 621 2184

Malcolm Ross 0192 576 6610

Martin Worgan 0168 429 5655



[Above] Bernie Langworth lands, Dave Robson fields and Peter Cannon flies on round. Dave Copeland retrieves errant model while pilot Dave Roberts takes a breather. John Bradley time-



[Left] Bernie Langworth and Dave Robson (now a Barton MFC member) teamed up for third place. Len Morrall and Cathy Eifflander share the good mood.

[Below] Peter Cannon, in action pitting, monitors pilot Derek (also now a Barton recruit)

[Bottom] Dave Hutchison (yet another recent Barton recruit) clutches first place trophies earned with team-mate Bernie Langworth.



More Racing

BARTON GOODYEAR MEETING **British Goodyear 1000 Lap Marathon** **30th September 2007**

[Weather: 15° C, wind SE 8 mph, sunny, dry, 90% cloud]

CD Andy Daghish reports:

What a turnout and what a lovely autumn day - nine teams all ready to go to complete 1,000 laps!

Just so things did not get too boring with the usual suspects winning everything, this time they seemed to meet with various technical problems - you name it, line breaks, line tangles etc. Nevertheless, Bernie Langworth managed to fly 2,000 laps without the aid of his pacemaker, while Malcolm Ross still seemed to be able to whip for 80% of his heat!

So what happened? Firstly, *Team Eifflander* managed to break a prop on their first stop - and it went downhill for them from there! After yet another prop breakage, they eventually retired on 429 laps. Better luck next year!

The other top-seed team of *Daghish/Worgan* - that's my younger brother, you know! - got a milk run start and a new record seemed on the cards with some quite impressive pit work and piloting. Yes, everything seemed to be going very nicely until lap 387, when a line broke at the bellcrank. So that meant that the two top teams were out!

Eyre/McPeake tried hard but things did not go their way either, ending with a retirement at 189 laps. Young Chris Eifflander decided to try his hand at the other end of the lines for a change by pitting for the even younger Tom Meager until, putting his hand into the prop at 160 laps, he deposited volumes of sticky red stuff everywhere, thus ending *Meager/Eifflander's* race.

Getting down to the last teams on the day, *Cannon/Cannon*, displayed more up and coming form by recording their personal best, completing their race in 1:01:00 exactly. (Well done!). However, below them, *Roberts/Copeland* only managed 2½ laps, having too many engine problems... but congratulations to all!

AD

BRITISH GOODYEAR 1,000 (9 entries)

Pos	Team	TIME
1.	Langworth/Hutchinson	50:00
2.	Ross/Court	50:21
3.	Langworth/Robson	51:41

Also flew: Eifflander/Eifflander; Daghish/Worgan; Eyre/McPeake; Meager/Eifflander; Cannon/Cannon; Roberts/Copeland

FLYING OFF AT A TANGENT

Frank Lee Speaking...

MUCH ADO ABOUT NOTHING ... or a petition

Most will know of the on-line petition to the Prime Minister "to make it compulsory for all local authorities to make provision for aeromodelling at county or local level" and, perhaps too, that it attracted all of 1,224 signatures by the deadline on 28th August. And now also will have realised the depressing answer – nix - to wit: "The Government is unable to get involved in the decision-making processes of local authorities and would advise aeromodelling clubs to approach councils and make their case as to how their activities may benefit their area on an individual basis."

But what did all those excitable petitioners ever expect? Now it seems we've blown it and the movement's collective vulnerability has been exposed all over again... and at the highest level. Critics of such petitions have sagely pointed out the overwhelming response there would be if, for example, petitioning in favour of the abolition of income tax. Imagine too the massive popular support there would be for football or fishing (or even for girls' netball, sport's notorious poor relation)!

Can you not visualise the scene in the PM's private office on 29th August 2007...

"Morning, Tristram!"

"Good morning, Seb! Look, I asked you to drop by this morning with those latest petition results because, as you know, the PM is very keen to boost his support in the constituencies and this Brian Winstanley chappie – he's got a lot of influence, y'know – well, he's convinced him that allocating funding to aeromodelling could be a goer. So let's have a look at what you've got, shall we? Will there be any votes in it?"

"Not looking too good, I'm afraid, Tris. There are nearly twice as many out there who wish to legalise pistols again."

"Nutters! But look, Seb, let's be positive. That is about as many as support building a £100 million mega-mosque and about the same number as those in favour of naming a ship 'HMS Iron Lady' in honour of Baroness Thatcher... or who want to award Brian Clough a posthumous knighthood. It's even a bit more than those who want to bring back Concorde and more than double those who want to 'facilitate provision of more clothing optional places'... Er, that's about swimming in the buff, isn't it?"

"Yah, but sorry, Tristram, this ain't going to go down well with the PM 'cos it's still less than the support for banning the sale of animal fur. What's more, 15 times as many are in favour of horses riding two abreast on public roads. Even worse..."

"Mmm...?"

"Twelve times as many have petitioned that Jeremy Clarkson be made PM!"

"Tell you what, Seb, let's put this on the back-burner for now. But can you dig out that one about the speed cameras?"

ROUNDABOUT... with Windle Smithers

Psst, you want tight lines?

The last issue of *Circle Talk* carried a photo of the slow flying Peacemaker that John Allcock flew at the BASH. It was noteworthy because of the extreme but obviously highly effective amount of sidethrust. This rang a bell and it didn't take too long to unearth one of the late George Aldrich's columns in *Model Aviation* in which he admits to being influenced by Howard Thomb's *Di-Doe* biplane old-timer that had some 15° engine offset, enabling it to be flown in any sort of weather.

To quote GMA: "Back in the late 1950s I adapted this large offset feature to one of my Flite Streaks, powered by an Oliver Tiger .15 diesel [in lieu of a 35 – WS]. It flew in 45 mph winds and had no problems with slack lines.

"But the trick feature of this Flite Streak was its ability to stay out on the lines when stalled, to the point that it could hang stationary at times. Often my helper would catch it, refill the tank and turn it loose again [presumably before the engine cut – WS].

"I recently finished a couple of Flite Streaks, utilizing the original [i.e. not the kit – Ed] construction to keep the weight down. The improved performance was well worth the effort and line tension, even with 60' stranded wires, is no problem.... Once a hot Combat ship, the Flite Streak becomes a real blast to fun-fly with less power up front." [This would be in keeping with current opinion in some US quarters that would suggest the OS 20FP as the engine of choice for aerobating a (lightly built) Flite Streak in preference to a Fox 35 – WS].

Looking again at the photo of John Allcock's Peacemaker with all that sidethrust, the fuel tank isn't canted and the feed pipe appears to come from the rear as usual. I don't recall John having other than an excellent engine run but it does conveniently lead us to a retread of something else...

Another sucker...

This from Ron Prentice's April '89 column in *Aeromodeller*: I mentioned to Tom Dixon that I was not getting a really good motor run from my PAW 1.49 in the Wee Duper Zilch. He has overcome the same problem in his scaled down Thunderbird, thanks to a front-feed hopper tank. [See diagram]. Tom says that this was the only way he could be sure of getting a constant-speed motor run."

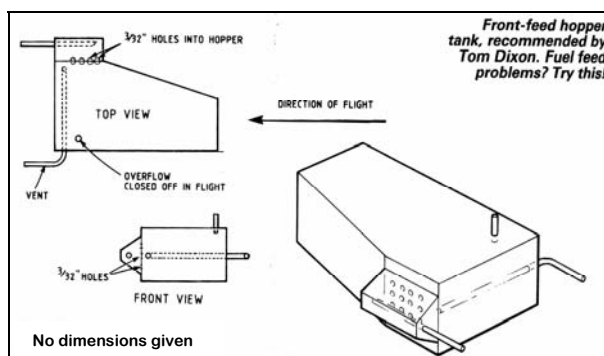

Stunt

2007 BARTON CUP MEETING

16th September 2007 at Barton

[Weather: 15-20° C, wind SW 15-18 mph, sunny, dry, 60% cloud]

CD Ray Lloyd reports:

Barton Cup F2B Stunt Saturday dawned a lovely day... and then Paul Winter and John Benzing turned up! No, that wasn't the reason for the bad weather next day— although I have heard that high pitched sounds can turn milk and cause hens to stop laying (and also John's height might have some influence on cloud formations). Certainly, when Sunday dawned, the weather was on the turn for the worse.



RL

With nine (eager?) pilots "trapped" (as we say up north), the wind was starting to rise and, worse still, it was coming off the buildings and trees behind the site. Nevertheless, Peter Jackson was the only casualty of the day when his model kissed the ground in a square bunt. I think all the damage was confined to the fuselage so the repair should be easier than a complete rebuild but, as he said, that's two in two months (because he previously had a nasty at the Nats—I know the feeling).

[Left] Paul suggested that I move to the down wind side of the circle as I might be the cause of some of the turbulence. Cheeky! I ask you, am I not fully streamlined? [Max camber's too far forward-Ed]

Barton Cup F2B Stunt (9 entries)

Pos	Pilot	Rnd 1	Rnd 2	Rnd 3	Score
1.	R Kitley	890.5	772.9	732.1	1,663.4
2.	R Cherry	725.7	801.3	808.2	1,609.5
3.	P Jackson	810.7	762.0	679.7	1,572.7
4.	P Winter	827.5	661.5	691.5	1,519.0
5.	I Galt	770.9	736.0	730.8	1,506.9
6.	W Draper	765.8	682.7	708.1	1,473.9
7.	P Miller	585.9	622.6	648.7	1,271.3
8.	J Benzing	747.2	-	-	747.2
9.	J Alcock	687.7	-	-	687.7

Acknowledgments

John Bonner presided as judge for the day while Jim Hatch tabulated throughout with the tabulating machine (i.e. new laptop) in the tabulation caravan. (See, Jim, don't I look after my staff?).



Ian Galt, Peter Miller, Bill Draper and John Alcock gather to watch Paul Winter fight the tricky breeze

Barton Handicap Stunt I also ran a fun event that I called "Barton Handicap Stunt". It involved no extra rounds but instead I used the fliers' average scores over the last 12 months from the results I had to hand to allot them handicaps for the day, thus creating a more level playing field. So the better fliers had to try harder and the lower scoring fliers were given an extra incentive to extend themselves. **RL**



Ian Galt responds to a heckler in characteristic style

Handicapped Results		
Pos	Name	Total
1	Paul Winter	1,971.0
2	Peter Miller	1,897.3
3	Ian Galt	1,742.9

[Below] These three ladies took up residence outside the tabulation caravan and spent the day there. (This picture was taken very early in the day before the wine started to flow). I can't imagine why but they quickly became affectionately referred to by the fliers as "THE COVEN"! L-R: Edna Alcock, Dot Dickinson and June Draper



RL

BMFA Centralised Competition

7th October 2007 at Barton

[Weather: 17° C, wind E 2 mph, sunny, dry, 10% cloud]

F2B & CLASS 2 AEROBATICS

CD Ray Lloyd reports:

This was a cracking day with perfect weather but only five flyers!

In Round 1 Bill Draper, Rob Kitley and Roy Cherry each put in scores in the 900 bracket, all good stuff.

In Round 2 Bill Draper only managed half a flight due to a temperamental motor but every one else improved their scores.

In Round 3 the heat was on: Bill scored 957.5, only a bat's tail feather behind Rob, while Barry Robinson put in a stonking flight to score 1,036.3 This was a killer and was to decide the first place, although Roy Cherry upped his game to score 994.5. However, for sheer consistency, look at Rob Kitley's scores.



The model of choice of that very model of consistency, Rob Kitley. (Ray thinks it's "one of Randy Smith's SV12 range").

In case you think that John Alcock is escaping without a proper mention—well, yer wrong! Many thanks to John, who always comes along and gives his support to the team. Pleased to see you, John!

Judge for the day was Jeff Smith, who sometimes takes a lot of stick because he jumps on badly performed manoeuvres. Well, mark this: in one flight he awarded three perfect tens! Make of that what you will but it does go to show that when Jeff sees a good manoeuvre he will mark it accordingly. **RL**

Pos	Pilot	Rnd 1	Rnd 2	Rnd 3	Score
1.	BP Robinson	887.0	947.5	1,036.3	1,983.8
2.	R Kitley	974.0	974.9	979.6	1,954.5
3.	R Cherry	930.6	933.6	994.5	1,928.1
4.	CW Draper	902.1	515.0	957.4	1,859.5
5.	J. Alcock	733.5	761.0	757.6	1,518.6

[Note: No entries received in Class 2 Aerobatics]



[Left] Speed enthusiast Richard Grindley takes the strain during pull test of his 154 mph K & B 40 speed model

[Right] Plenty of time on a windless sunny day for a bit of fun and Rob Simpson, newly returned to the fold, seemed to be having some with this Japanese kitted trainer from Paul Winter. Richard Grindley gives a welcome helping hand.



[Left] Looking a little like a fearsome relic from a mediaeval joust, it's Ken Morrissey's F2A handle



[Right] A Hornet 60, a classic vintage speed engine, changes hands between Tom Hughes [L] and Rob Cheshire

SPEED Results provided by Jo Halman

POS	NAME	RECORD		ROUND ONE		ROUND TWO		ROUND THREE		BEST SPEED		
		Class	Secs	Secs	Kph	Secs	Kph	Secs	Kph	Kph	Mph	%
1	Peter Halman	F2A	12.01	12.16	295.86	Did not fly		Did not fly		295.86	183.84	98.80
2	Ken Morrissey	F2A	12.01	12.93	278.36	12.74	282.5	12.58	286.08	286.08	177.76	95.50
3	Richd Grindley	F40	12.05	No start		16.52	217.86	14.51	247.97	247.97	154.08	83.07

'HELL RAZOR' by George Fong

159.63 mph AMA Record, 1949 (Dooling 61)

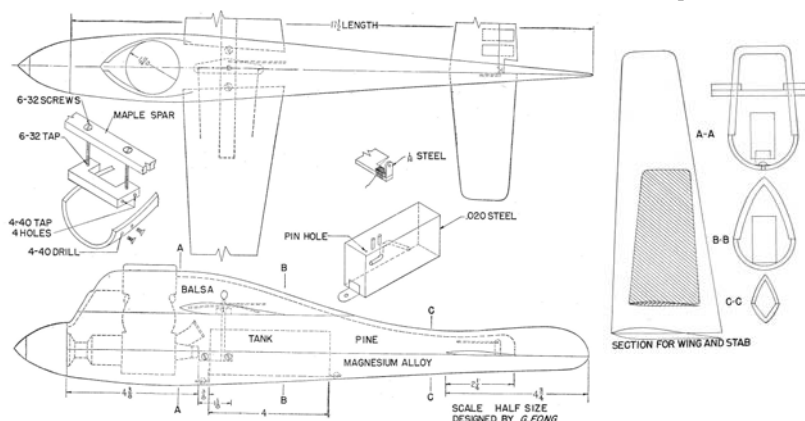

This three-view is dedicated to Geoff Walker, who told us he owned a magnesium Hell Razor pan but had no drawing. After we rooted out a copy of the November 1949 Model Airplane News article for him, we found out his pan was for a 29!

George Fong said that progressively going from all wood construction to a metal pan increased the weight from 26 to 32 oz but upped the speed from 133 mph to the 1959 record. The engine a "standard" Dooling, using the manufacturer's recommended fuel, and prop a standard Rev-Up 9"x 13". Note the intentional absence of any cooling air outlet, but the inlet vee was "important".

Geoff is keen to have some regular speed sessions and informal club comps flown over the grass at Barton with other members interested in CL Speed. He is willing to be the coordinator if any interested parties would care to get in touch with him to progress things.

And Yet More Racing!

BARTON GOODYEAR MEETING British and Open Goodyear 14th October 2007

[Weather: 16° C, wind SW 8 mph, sunny, dry, 90% cloud]

CD Andy Daghish reports: Well, what a great day (again)! Seven entries in Open Goodyear and an amazing ten in British Goodyear!

With many teams 'double-entering' just to add to the fun of it all, it was fortunate that most of them were happy with the times achieved in the First Round, thus helping to make life a little easier in the Second. Nearly all put in a time, even Sam Simon with a staggering 7:14:04. (Well done, Sam!). On being asked whether he wanted another go in the second round, Sam's reply was "No, my legs won't stand it!"

As it happened, there was less carnage at this event than at the recent "Marathon" – always a good thing. Certainly, everything ran nice and smoothly. It was interesting to see Tony Eifflaender experimenting with a 3.5 cc PAW in an Open Goodyear model. Although not legal, I felt that this could have won the Final had the needle valve stayed intact. Not only were Tony's pit stops very, very good, but also the airspeed, although I didn't actually time it, appeared awesome.

Finally, a word about the British Goodyear Final, which was won by the father/son team of Eifflaender/Eifflaender, followed home by Catlow/Jephcott, who lost 30 seconds when their plane ran into the circle at a pit stop. Langworth/Hutchison claimed

third after disqualification for jettisoning a wheel.

I think everyone enjoyed the day as much as I did even though, lacking his regular pilot, Mr. Worgan appeared to be at something of a loose end. Indeed, many expressed disappointment that there would not be another Barton racing day until the "Cold Turkey" events on Friday, 28th December. But I'll see you there! **AD**

OPEN GOODYEAR (7 entries)

Pos	Team
1.	Catlow/Jephcott
2.	C. Eifflaender/Worgan
3.	Langworth/A. Eifflaender

BRITISH GOODYEAR (10 entries)

Pos	Team
1.	Langworth/Hutchison
2.	Catlow/Jephcott
3.	Eifflaender/Eifflaender

OCTOBER BARTON GOODYEAR DAY PHOTO CAPTIONS from opposite page

1. Familiar panoramic racing scene at Barton with **Paul McPeake** about to field OGY model in front of the usual background of intent spectators.
2. It's a family affair – **Cathy Eifflaender** presents silverware to BGY winners **Chris** and **Tony**.
3. Begone! **Peter Jephcott** gets OGY winner away after another good pit stop.
4. **Dave Hutchison** regularly travels all the way down from Kirkcaldy to fly at Barton. That's almost 300 miles each way!
5. Just like the Spanish Inquisition, "no one escapes" from **Len Morrall's** club raffles. Here, prize winner **Sam Simon** picks out another ticket that just happens to belong to **Peter Jephcott** watching in the background. (No, it wasn't a fix!).
6. These three OGY racers from the Nats were also at Barton. L-R: **Peter Jephcott's** Barton winner and models by **Lawrence Court** and **Paul McPeake**.
7. Most of the gang... L-R: **Derek** and **Peter Cannon**, **Ian Taylor**, **Peter Jephcott** and **John Catlow**, **Richard Grindley**, **Len Morrall**, **Martin Worgan**, **Andy Daghish (CD)**, **Paul McPeake**, **Tom Meager**, **Dave Hutchison**, **Dave Robson**, **Mike Bellamy**, **Bernie Langworth**, **Nev Eyre**, **Mike Crossman**, **Lawrence Court** and **Chris**, **Cath** and **Tony Eifflaender**.



NOTICE BOARD

December Club Night

Please note that this will be on the *first* Friday of December (7th) at *The Brown Cow*. This is just this once and due to a double booking. Bring along that new model/engine and tell all!

Barton "Cold Turkey"

Friday, 28th December 2007, 10:00 am

The scheduled events comprise:

- British Goodyear
- Mini Goodyear
- Barton B
- Club Speed (*See note below*)

Rules clarification for Club Speed

1. Any standard plain bearing diesel or glow engine up to 1.5 cc/.09 cu in
2. Line length 13.5 m (i.e. as MGY)
3. Any model in keeping with the spirit of the rules will be eligible
4. This is intended to be a fun event!

For further information about the day's events, contact Malcolm Ross (0192 576 6610)

Esso Blue Paraffin

The Wharfedale club have acquired a dealer's stock of genuine Esso Blue Paraffin that they will be making available on the airfield at the 2007 Barton "Cold Turkey" meeting, price £4.00 per gallon. Please bring your own containers!

Barton Ladies' Night

Friday, 11th January 2008, 7:30 pm
Boysnape Hall Golf Club, Irlam

Numbers limited to 75. Cheque to Malcolm Ross by 14th Dec at latest to book, stating choice of food. Two courses £14.50, three courses 16:50.

Starter: Chef's Homemade Soup of the Day

Main: Choice of (1) Pan fried steak in creamy peppercorn sauce (2) Poached salmon [V] with Hollandaise sauce (3) Mushroom Stroganoff [V]

Dessert: Choice of (1) Profiteroles with cream (2) Cheesecake with cream

Contacting CIRCLE TALK?

Editorial content and on-line distribution:

Peter Branigan

1, St. Georges Road, Formby,

Liverpool L37 3HH Tel: 01704 834224

E-mail: peter.branigan@btinternet .com

Paper printing and postal distribution:

Brian & Pat Winstanley Tel: 0125 452196

E-mail: ivory2@tiscali.co.uk

BARTON MFC Who's Who?

Chairman

Lawrence Court *Tel: 01204 573694*

Hon. President:

Brian Winstanley *Tel: 0125 452 196*

Secretary:

Malcolm Ross *Tel: 0192 576 6610*

8 Birchall Avenue, Culcheth,

Warrington WA3 4DB

E-mail: mcross88@talktalk.net

Treasurer & BMFA Subs:

Patricia Winstanley *Tel: 0125 452 196*

Public Relations:

John Whiteside *Tel: 01254 824807*

Flying Site Manager:

Ian Taylor *Tel: 0161 865 4602*

Hard Circle Development:

Ken Morrissey *Tel: 0161 437 9794*

Barton Events Calendar:

Ray Lloyd *Tel: 0170 621 2184*

Social Events:

Len Morrall *Tel: 0170 634 1495*

Safety Officer/Web Site Administrator:

Jim Hatch *Tel: 0125 470 8415*

Club Photographer:

Fred Hall *Tel: 0161 748 4391*

Essential Do and Don'ts!

Carry your Barton and BMFA membership cards at all times when on site.

Lock the gate after yourself on entry and exit

DO NOT leave the lock set to the combination

OR divulge the gate code to any non-member.

Flag: *Put up the flag BEFORE you fly.*

Take it down BEFORE you leave!

Airstrip: *DO NOT CROSS THE RUNWAYS or enter active areas without express permission from Barton Tower at any time when the airfield is operational .*

Police helicopter: *Land or fly low WHENEVER the police helicopter is operating nearby.*

Report all emergencies to the Barton Tower

Telephone: 0161 787 7326

First aid kit: *Always kept in the container.*

Mower & dumper: *DO NOT OPERATE these or any other club machinery without prior instruction AND clearance from a Committee member.*

Leave no litter: *TAKE IT HOME WITH YOU!*

Check the weather: *Dress appropriately. (48 hr forecast for M30 at www.metcheck.com)*